

# SPEEDBLADE

Speedblade – is a type of motorized gate featured with retractable flaps operation principle. Housing materials and light weight cabinets' shape make Speedblade speed gate universal for large variety of facilities with heightened requirements to esthetic equipment appearance. As well as other TiSO speedgates, Speedblade has implemented anti-tailgating and other safety and security functions. Normal and wide lanes for disabled people can be arranged through cabinets with same sizes. Turnstiles can be operated from remote control panel or via access control system.



## MOTORIZED SPEED GATES FEATURED WITH RETRACTABLE GLASS LEAVES



### Key features:

- BMDrive® - Reliable mechanism with powerful BLDC gear motor ensures long term maintenance-free operation;
- Speed gate equipped with smart self-diagnosing system;
- Innovative controller with OLED display and buttons for easy setup and configuration without special programmers;
- Digital control of force and leaf speed in combination with safety sensors prevent person from being struck by a leaf, even in case of an unauthorized passage;
- Sensor system allows detecting the passage of person with luggage, or arranging a free exit without the need for identification;
- Elegant cabinets equipped with integrated LED lighting showing access status and card reader area;
- Same dimensions of cabinet for normal (550 mm) and wide lane (900 mm);
- The ability to customize housing design and top lid;
- Low power consumption;
- Can be integrated with any type of access control systems;
- Wired remote control panel in standard kit;
- In case of power failure, leaves could be opened manually (fail-safe).

\*optional



www.tiso.global  
+380 (44) 291-21-11  
e-mail: sales@tiso.global



## Technical Specifications:

| Model                       | Speedblade 550  | Speedblade 900 |
|-----------------------------|---|----------------|
| Cabinet width, mm           | 295   |                |
| Cabinet length, mm          | 1005  |                |
| Cabinet height, mm          | 1000  |                |
| Passage width, mm           | 550   | 900            |
| Opening/closing time, sec   | 0,5   | 0,8            |
| Mechanism                   | BMDrive® servodrive (BLDC)                            |                |
| Blocking system             | DeadLock®   |                |
| Emergency mode (fire-alarm) | Free entry/exit (leaves are opened automatically)     |                |
| Power fail                  | Fail safe (gates could be opened manually — standard) |                |
| MCBF, cycles                | 10 000 000  |                |

## Electrical Specifications:

|                              |  |
|------------------------------|--|
| Maximum power consumption, W | 160  |
| Voltage                      | From the AC (100-240)V, 50/60Hz; from a DC source 12 V |
| Indication                   | DotLights®, RFIDLights®, EdgeLights® FloorLights®      |

## Finishing

|                   |  |
|-------------------|--|
| Standard housing  | Brushed SS AISI 304  |
| Available housing | Brushed SS AISI 316; Polished SS AISI 304; Polished SS AISI 316; Powder coated RAL |

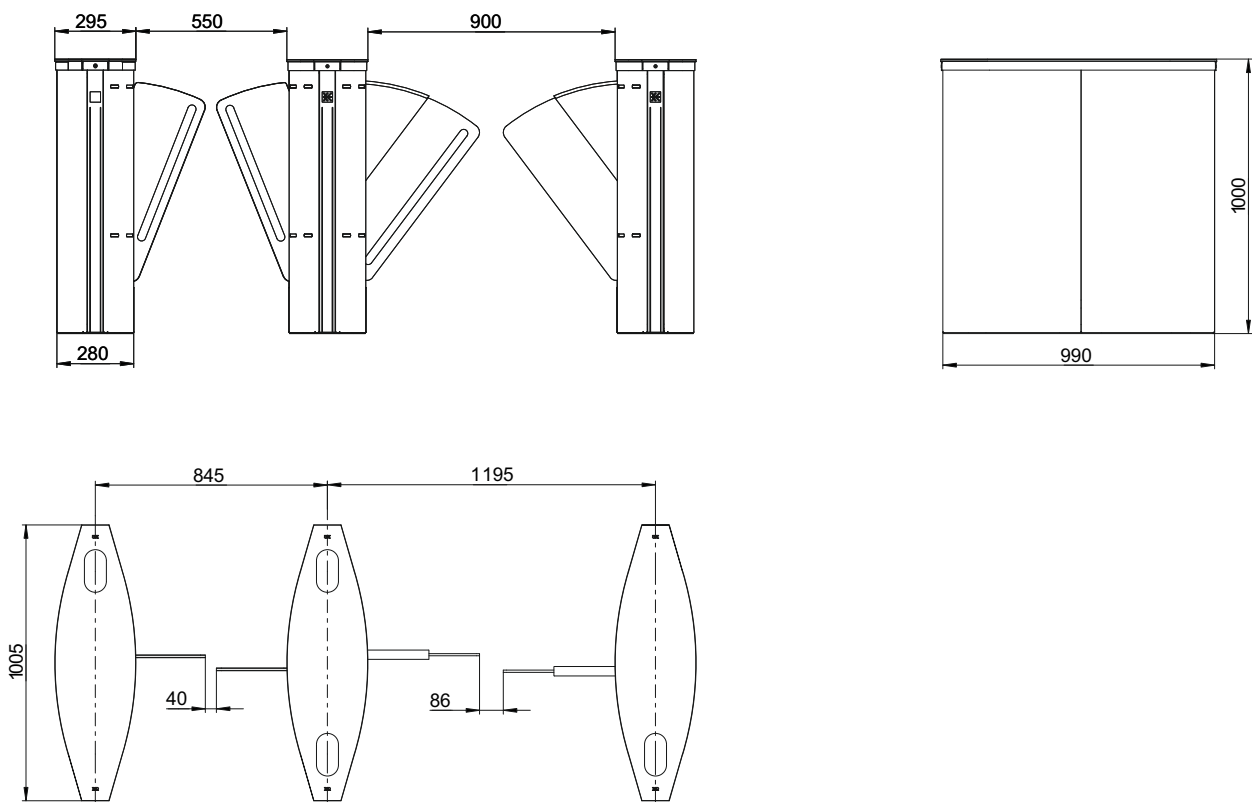

Dimensions for solid glass top lid

Specifications are subject to change without prior notice.

